



Available online at <http://scik.org>

Commun. Math. Biol. Neurosci. 2015, 2015:26

ISSN: 2052-2541

## ECO-EPIDEMIOLOGICAL MODEL AND OPTIMAL CONTROL OF DISEASE TRANSMISSION BETWEEN HUMANS AND ANIMALS

CHRISTOPHER SAAHA BORNA<sup>1,\*</sup>, OLUWOLE DANIEL MAKINDE<sup>2</sup>, IBRAHIM YAKUBU SEINI<sup>1</sup>

<sup>1</sup>Department of Mathematics, Faculty of Mathematical Sciences, University for Development Studies,  
Navrongo Campus, Ghana

<sup>2</sup>Faculty of Military Science, Stellenbosch University, Private Bag X2, Saldanha 7395, South Africa

Copyright © 2015 Borna, Makinde and Seini. This is an open access article distributed under the Creative Commons Attribution License, which permits unrestricted use, distribution, and reproduction in any medium, provided the original work is properly cited.

**Abstract.** In this paper, a nonlinear mathematical model is proposed to study the dynamics of disease transmission between human beings and animals. The disease free equilibrium is established and it is locally asymptotically stable if the basic reproduction number  $R_0 < 1$ . To determine how a marginal change in any one of the parameters in  $R_0$  would impact on the prevalence of the infection, a sensitivity analysis is carried out by using the Forward Normalized Sensitivity Index. We then modify the basic model into an optimal control problem by incorporating three controls to check the spread of the disease. These controls are grouped into curatives and preventives. It shows that a combine effort of both curatives and preventives is necessary to combat the disease. Numerical simulations are also provided to illustrate the mathematical results. Finally, various options of combinations of the controls are examined to determine the most cost effective combination that can control the infection by using the Incremental Cost-Effectiveness Ratio. It indicates that the combine effort of curatives and preventives is preferable but the preventive is better than the curative strategies.

**Keywords:** Mathematical modeling; Basic reproduction number; equilibrium; stability; next generation matrix; optimal control theory.

**2010 AMS Subject Classification:** 92B05, 93A30, 93C15.

---

\*Corresponding author

E-mail address: [chrisbornaa@gmail.com](mailto:chrisbornaa@gmail.com)

Received January 29, 2015

## 1. Introduction

Health is a very significant ingredient in the life of every living thing. It is estimated that about 75% of human infectious diseases are transmitted from both domestic and wildlife animals [1]. People most at risk of contracting such diseases, sometimes referred as zoonotic diseases, are those in close contact with animals or animal products such as veterinarians, pet owners, abattoir workers, farmers, etc. For this reason many have placed more emphasis on the relationship between the health systems of human beings and animals. Local provisions in animal research centres and international established institutions such as Centre for Disease Control and Prevention (CDC), World Health Organisation (WHO) among others were established to monitor and take care of emergency health issues and pandemics.

Mathematical modelling employed at various levels and aspects of ecological studies [2, 3] is a very useful tool for studying the nature of nonlinear interaction among species of various animals. This study therefore employs the technique mathematical modelling to investigate the transmission dynamics of zoonotic disease. Hsieh and Hsiao [4] stated that the population of animals, including human beings, are significantly controlled by infectious diseases. The threat of the flu virus, mad cow disease, rabies, etc on human life and the recent outbreak of the deadly Ebola virus in the West African sub - region shows the possibility of a pandemic. It is therefore vital to search for measures of controlling such infectious diseases.

Many studies such as [5], have indicated that infection can be eradicated from an ecosystem through treatment by administering drugs. Other interventions which include vaccination, quarantine, education etc were equally suggested for the management of diseases [6, 7, 8]. The term quarantine is used here to denote the conscious attempt to isolate both symptomatic and non-symptomatic infected species from a population of susceptible species. Vaccination is rather the introduction of a dormant pathogen of an infectious disease into a susceptible population. This allows the vaccinated animal to produce antibodies against the weaker pathogen so as to develop immunity. Education, for the purpose of this study, is the campaign to bring about awareness of the disease, its mode of transmission, prevention and control within the population.

Even though these suggested controls may look potent, their ability to curtail an epidemic is dependent on the rate at which a single infected individual reproduces itself in the population

within a specific time frame and the amount of an intervention that is applied. This also has a cost implication. However, there is a huge economic resource constraint with the population explosion in the world. Therefore there is the need to select the best possible means of combination of the various interventions to minimize the cost of implementation.

One other thing that is very important in epidemiological investigations is the reproduction number. It plays a vital role in the analysis of models thereof. It defines the average number of new cases of an infection caused by one typical infected individual in a population consisting of susceptibles only. It is one of the means used to determine whether or not an infection can easily be controlled. In this study, the New Generation Method to determine the reproduction number is proposed.

## 2. Model formulation

In this section a mathematical model is developed to study the dynamics of zoonotic diseases such as foot and mouth diseases in cattle, Ebola virus, flu, and mad cow disease, etc which are known to originate from both domestic and wild animals. It will be assumed that in this model the human population represents the predator while the animal population represents the prey. The dynamics will therefore follow the Michaelis-Menten kinetics Holling type-II predation function. This functional response refers to the predation rate as a function of the number of animals per human predator. It is known that as the number of animals increases, the rate of animal capture per human predator cannot increase indefinitely. Instead, the rate of animal capture is saturated when the population of animals is relatively large. On this note,  $N_1(T)$  represents the total population density of the animal species with  $S(T)$  and  $I(T)$  as the population classes and  $N_2(T)$  denotes the population density of the human beings with  $Y(T)$  and  $Z(T)$  as the population classes. The model is then divided into four compartmental groups as the susceptible animals, infected animals, susceptible individuals and infected individual groups represented by  $S$ ,  $I$ ,  $Y$ , and  $Z$  respectively.

The model is formulated with the following assumptions:

- (i) In the absence of the disease, the susceptible animal (prey) population grows logistically with intrinsic growth rate  $r_1$ , environmental carrying capacity  $K$ , ( $r_1, K \in R_+$ ) and decreases in the population due predation rate of  $n$ .
- (ii) Only the susceptible  $S(T)$  can procreate. Logistic law is then use to model the birth process with the assumption that births should always be positive.
- (iii) The infected animals  $I(T)$  is remove with a death rate  $c$  or by human predation before they can possible reproduce. However, both the infected  $I(T)$  and susceptible  $S(T)$  animals populations contribute to the population growth towards the carrying capacity  $K$ .
- (iv) Susceptible animals  $S(T)$  become infected through contact with an infected animal  $I(T)$  and this contact process is assume to follow the simple mass action kinetics with  $\beta$  as the rate of transmission.
- (v) The disease can cross species barrier from the animal population  $N_1(T)$  to the human population  $N_2(T)$ . Hence the susceptible predator(human),  $Y(T)$ , adds up to the infected predator,  $Z(T)$ , through predation and/or contact with the infected and it is not genetically inherited.
- (vi) The infected human  $Z(T)$  population can recover by treatment at the rates  $\gamma$  and possesses a death rate of  $(\sigma + \mu)$ , where  $\sigma$  and  $\mu$  are the death rates due to infection and nature respectively.
- (vii) The predation functional response of the human being towards both susceptible  $S(T)$  and infected  $I(T)$  animals are assume to follow Michaelis-Menten kinetics and is modelled using a Holling type-II functional form with predation coefficients  $b$ , ( $b > 0$ ) and half-saturation constant  $a$ , ( $a > 0$ ).
- (viii) The efficiency at which the consumed susceptible  $S(T)$  and infected  $I(T)$  animals (prey) are converted into predator is given as  $p$  and  $q$  respectively, where  $0 < p < 1$  and  $0 < q < 1$ .

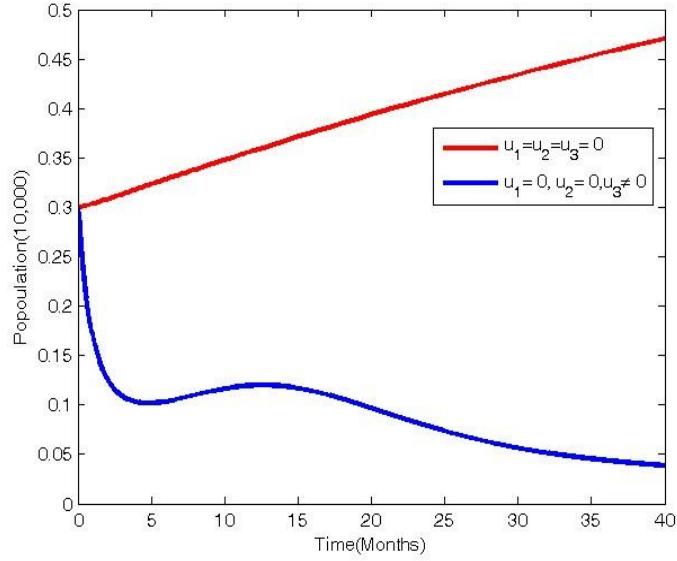

FIGURE 1. Flowchart of the model

The following set of ordinary differential equations represents the model:

$$(1) \quad \begin{cases} \frac{dS}{dT} = r_1 S \left(1 - \frac{S}{K}\right) - \beta SI - \frac{nSY}{aY+S} \\ \frac{dI}{dT} = \beta SI - \frac{bIY}{aY+I} - cI \\ \frac{dY}{dT} = \frac{pnSY}{aY+S} - \mu Y + \gamma Z \\ \frac{dZ}{dT} = \frac{qbIY}{aY+I} - (\sigma + \mu + \gamma)Z \end{cases}$$

With initial data values  $S(0) \geq 0, I(0) \geq 0, Y(0) \geq 0, Z(0) \geq 0$ .

The number of parameters in the model poses a challenge in the determination of the combination of parameters that control the behaviour of the system. Hence, we non-dimensionalize the system (1) to reduce the number of parameters. Assume  $s = \frac{S}{K}, i = \frac{I}{K}, y = \frac{aY}{K}, z = \frac{Z}{K}$  and  $t = \beta KT$ .

$$(2) \quad \begin{cases} \frac{ds}{dt} = rs(1-s) - si - \frac{msy}{y+s} \\ \frac{di}{dt} = si - \frac{giy}{y+i} - cli \\ \frac{dy}{dt} = \frac{pmsy}{y+s} - \mu yl + \gamma zl \\ \frac{dz}{dt} = \frac{qgiy}{y+i} - (\sigma + \mu + \gamma)zl \end{cases}$$

where  $r = \frac{r_1}{\beta K}$ ,  $g = \frac{b}{\beta K}$ ,  $m = \frac{n}{\beta K}$  and  $l = \frac{1}{\beta K}$ ; with initial data values  $s(0) \geq 0$ ,  $i(0) \geq 0$ ,  $y(0) \geq 0$  and  $z(0) \geq 0$ .

### 3. Boundedness

For the system to be biologically valid and well behaved in a theoretical eco-epidemiology, all its solution must be within a certain region of confinement. This will only happen if the following theorem is satisfied.

**Theorem 3.1** *All the solutions of the system (2) are uniformly bounded within  $\mathfrak{R}_+^4$*

**Proof.** Assume  $\{s(t), i(t), y(t), z(t)\}$  to be any solution of system (2).

We consider  $W = s + i + y + z$ . Therefore  $\frac{dW}{dt} \leq \hat{k}(r+1) - hW$ . where  $\hat{k} = \max\{s(0), k\}$  and  $h = \min\{1, c, \mu, \sigma\}$ . Applying the theorem of differential inequalities, the solution to  $\frac{dW}{dt} + hW \leq \hat{k}(r+1)$  is given as  $W \leq \frac{\hat{k}}{h}(r+1)(1 - e^{-ht})$ . As  $t \rightarrow \infty$ ,  $W \leq \frac{\hat{k}}{h}(r+1)$ . This implies that the solution is bounded for  $0 \leq W \leq \frac{\hat{k}}{h}(r+1)$ . It shows that all the solutions of model (2) in  $\mathfrak{R}_+^4$  are confined in the region  $\tau = \{(s, i, y, z) \in \mathfrak{R}_+^4 : W \leq \frac{\hat{k}}{h}(r+1) + \varepsilon\}$  for all  $\varepsilon > 0$  and  $t \rightarrow \infty$ . Therefore the theorem is satisfied

This shows that we can sufficiently study the dynamics of the model within  $\tau$  and hence consider the model to be epidemiologically and mathematically well formed within  $\tau$ .

## 4. Equilibrium states of the model

### 4.1 Disease free equilibrium states

The disease-free equilibrium point results when there are no infectives, i.e., ( $i = z = 0$ ). Setting  $i = z = 0$  in the model and solving for  $s$  and  $y$ , we obtain the equilibrium point,  $B_E(S^*, 0, Y^*, 0)$ ,

$$\text{where } S^* = \left\{1 - \frac{pm - \mu l}{rp}\right\} \text{ and } Y^* = \frac{pm - \mu l}{\mu l} \left\{1 - \frac{pm - \mu l}{rp}\right\}.$$

The Disease free equilibrium (DFE),  $B_E(S^*, 0, Y^*, 0)$  does exist if and only if:

- (i)  $pm - \mu l < rp$
- (ii)  $0 < \mu l < pm$ .

From the original system it implies that DFE exists if and only if:

- (i)  $0 < \mu < pn$
- (ii)  $pn - \mu < r_1 p$ .

Where  $p$  is the rate of conversion of the susceptible animal (prey) into human predator,  $n$  is the predation rate of the susceptible animals,  $r_1$  is the logistic intrinsic growth rate of the animal and  $\mu$  is the rate of natural death.

### 4.2 Endemic equilibrium state

The equilibrium state of co-existence  $E_c(S^{**}, I^{**}, Y^{**}, Z^{**})$  is obtain by solving the model equation (2) for the non-zero sizes of the sub-populations. After some algebraic manipulations we get:

$$S^{**} = \frac{Z^{**}l(\sigma + \mu + \gamma) + cqI^{**}}{qI^{**}}, \quad Y^{**} = \frac{Z^{**}I^{**}l(\sigma + \mu + \gamma)}{qgI^{**} - Z^{**}l(\sigma + \mu + \gamma)}, \quad \text{where } I^{**} = \frac{rS^{**}(1 - S^{**}) + Y^{**}(r - rS^{**} - m)}{(S^{**} + Y^{**})}$$

$$\text{and } Z^{**} = \frac{\mu l Y^{**2} + (\mu l - pm) S^{**} Y^{**}}{\gamma l (Y^{**} + S^{**})}. \text{ Hence the endermic equilibrium state does exist if:}$$

$$qgI^{**} > Z^{**}l(\sigma + \mu + \gamma), \quad (S^{**} + Y^{**}) > \frac{mY^{**}}{r(1 - S^{**})} \text{ and } \mu l > pm.$$

## 5. Reproduction number and stability analysis

### 5.1 Determination of the reproduction number ( $R_0$ )

Our model has two infected states  $\frac{di}{dt}$  and  $\frac{dz}{dt}$  and two uninfected states,  $\frac{ds}{dt}$  and  $\frac{dy}{dt}$ . if we set  $\tilde{X} = (I, Z)^T$ , where T is the transpose, the linearized infection subsystem can be written as:

$$(3) \quad \frac{d\tilde{X}}{dt} = (F - V)\tilde{X}$$

Where the matrix  $F$  represents the transmission matrix and  $V$  represents the transition matrix. The transmission constitutes all epidemiological events that involve new infections and all other events are incorporated in  $V$ .

Hence we have

$$F = \begin{bmatrix} s - \frac{gy^2}{(y+i)^2} & 0 \\ \frac{gy^2}{(y+i)^2} & 0 \end{bmatrix}$$

and

$$V = \begin{bmatrix} cl & 0 \\ 0 & (\sigma + \mu) + \gamma l \end{bmatrix}.$$

At the DFE of our model

$$F = \begin{bmatrix} s^* - g & 0 \\ qg & 0 \end{bmatrix}.$$

Hence the next generation matrix is

$$G = F = FV^{-1} \begin{bmatrix} \frac{s^* - g}{cl} & 0 \\ \frac{qg}{cl} & 0 \end{bmatrix}.$$

The basic reproduction number,  $R_0$  is the dominant Eigen value of  $G$ , given by

$$(4) \quad R_0 = \frac{rp(1 - g) - (pm - \mu l)}{clrp}$$

By Theorem (2) of [9], the following result is established.

**Theorem 5.1.** *The disease-free equilibrium state,  $B_E(S^*, 0, Y^*, 0)$  of model (2) is locally asymptotically stable if  $R_0 < 1$ , otherwise it is unstable.*

This theorem presupposes that with  $R_0 < 1$ , the disease can be eradicated if the initial population is within the restricted region because an introduction of one infectious individual will generate, on average, less than one infection and this will not therefore cause an epidemic in the population. The disease will however be difficult to manage if  $R_0 > 1$ . The threshold value of



$R_0$  is hence known to be  $R_0 = 1$ .

## 5.2. Stability analysis

The local stability will be established by using the Jacobian matrix ( $J$ ) of the model equation (2), where

$$(5) \quad J = \begin{bmatrix} \frac{\partial f}{\partial s} & \frac{\partial f}{\partial i} & \frac{\partial f}{\partial y} & \frac{\partial f}{\partial z} \\ \frac{\partial g}{\partial s} & \frac{\partial g}{\partial i} & \frac{\partial g}{\partial y} & \frac{\partial g}{\partial z} \\ \frac{\partial h}{\partial s} & \frac{\partial h}{\partial i} & \frac{\partial h}{\partial y} & \frac{\partial h}{\partial z} \\ \frac{\partial k}{\partial s} & \frac{\partial k}{\partial i} & \frac{\partial k}{\partial y} & \frac{\partial k}{\partial z} \end{bmatrix}$$

The Jacobian matrix of the model (2) is therefore given as:

$$(6) \quad J = \begin{bmatrix} r(1-2s) - i - \frac{my^2}{(y+s)^2} & -s & -\frac{my^2}{(y+s)^2} & 0 \\ i & s - \frac{gy^2}{(y+i)^2} - cl & -\frac{gy^2}{(y+i)^2} & 0 \\ \frac{pmy^2}{(y+s)^2} & 0 & \frac{pms^2}{(y+s)^2} - \mu l & \gamma l \\ 0 & \frac{qgy^2}{(y+i)^2} & -\frac{qgi^2}{(y+i)^2} & -(\sigma + \mu + \gamma)l \end{bmatrix}$$

The disease-free equilibrium state of  $B_E(S^*, 0, Y^*, 0)$  will be investigated by using ( $J$ ). The Jacobian matrix ( $JB_E$ ), when  $B_E$  is substituted into equation (6) is given by:

$$JB_E = \begin{bmatrix} r \frac{2(pm-\mu l)}{rp} - 1 - \frac{(pm-\mu l)^2}{p^2m} & 1 - \frac{(pm-\mu l)}{rp} & -\frac{(\mu l)^2}{p^2m} & 0 \\ 0 & 1 - \frac{(pm-\mu l)}{rp} - g - cl & 0 & 0 \\ \frac{(pm-\mu l)^2}{pm} & 0 & \frac{(\mu l)^2}{pm} - \mu l & \gamma l \\ 0 & qg & 0 & -(\sigma + \mu + \gamma)l \end{bmatrix}$$

The Eigen values are obtain by evaluating the determinant of the matrix  $JB_E$ .

$$\det(JB_E) =$$

$$\begin{vmatrix} r \frac{2(pm-\mu l)}{rp} - 1 - \frac{(pm-\mu l)^2}{p^2m} - \lambda & 1 - \frac{(pm-\mu l)}{rp} & -\frac{(\mu l)^2}{p^2m} & 0 \\ 0 & [1 - \frac{(pm-\mu l)}{rp} - g - cl] - \lambda & 0 & 0 \\ \frac{(pm-\mu l)^2}{pm} & 0 & [\frac{(\mu l)^2}{pm} - \mu l] - \lambda & \gamma l \\ 0 & qg & 0 & -(\sigma + \mu + \gamma)l - \lambda \end{vmatrix}$$

$$= 0$$

$$\det(JB_E) = \left[1 - \frac{pm-\mu l}{rp} - g - cl - \lambda\right] - (\sigma + \mu + \gamma)l - \lambda(b_2 + b_1\lambda + \lambda^2) = 0,$$

$$\text{where } b_1 = r\left(1 - \frac{2(pm-\mu l)}{rp}\right) + \frac{(pm-\mu l)^2}{p^2m} + \mu l \frac{pm-\mu l}{pm},$$

$$b_2 = \mu l \frac{pm-\mu l}{pm} \left\{r\left(1 - \frac{pm-\mu l}{rp}\right)\right\}.$$

$$\text{But } clR_0 = 1 - \frac{pm-\mu l}{rp} - g.$$

$$\text{Therefore } \det(JB_E) = [clR_0 - 1 - \lambda] - (\sigma + \mu + \gamma)l - \lambda(b_2 + b_1\lambda + \lambda^2)$$

$$\lambda = \begin{bmatrix} cl(R_0 - 1) \\ -(\sigma + \mu + \gamma)l \\ \frac{-b_1 - \sqrt{b_1^2 - 4b_2}}{2} \\ \frac{-b_1 + \sqrt{b_1^2 - 4b_2}}{2} \end{bmatrix}$$

For the roots of  $\frac{-b_1 \pm \sqrt{b_1^2 - 4b_2}}{2}$  to have negative real parts

$$(i) \ b_1 > 0,$$

$$(ii) \ b_2 > 0$$

Conditions (i) and (ii) are true if and only if  $2(pm - \mu l) < rp$ . With these conditions and by applying theorem 5.1, the disease free equilibrium of system (2) is locally asymptotically  $R_0 < 1$ .

The endemic equilibrium state is also investigated by substituting  $E_C(S^{**}, I^{**}, Y^{**}, Z^{**})$  into equation (6):

$$\text{Assume that } JE_C = \begin{bmatrix} C_1 & C_2 & C_3 & 0 \\ C_4 & C_5 & C_6 & 0 \\ C_7 & 0 & C_8 & \gamma l \\ 0 & C_9 & C_{10} & -(\sigma + \mu + \gamma)l \end{bmatrix}$$

where

$$C_1 = r(1 - 2s) - i - \frac{my^2}{(y+s)^2}$$

$$C_1 = \left( \frac{qI^{**}(2rcl + r - I^{**}) - 2rZ^{**}l(\sigma + \mu + \gamma)}{qI^{**}} \right) - m \left( \frac{qZ^{**}I^{**2}(\delta + \mu + \gamma)}{[Z^{**}(\delta + \mu + \gamma) + cqI^{**}][qgI^{**} - Z^{**}l(\sigma + \mu + \gamma)] + qZ^{**}I^{**2}(\sigma + \mu + \gamma)} \right)^2$$

$$C_2 = -s$$

$$C_2 = -\frac{l[Z^{**}(\delta + \mu + \gamma) + cqI^{**}]}{qI^{**}}$$

$$C_3 = -\frac{ms^2}{(y+s)^2}$$

$$\begin{aligned}
C_3 &= -m \left( \frac{[Z^{**}(\delta+\mu+\gamma)+cqI^{**}][qgI^{**}-Z^{**}l(\delta+\mu+\gamma)]}{[Z^{**}(\delta+\mu+\gamma)+cqI^{**}][qgI^{**}-Z^{**}l(\sigma+\mu+\gamma)]+qZ^{**}I^{**2}(\sigma+\mu+\gamma)} \right)^2 \\
C_4 &= i \\
C_5 &= s - \frac{gy^2}{(y+i)^2} - cl \\
C_5 &= \frac{Z^{**}l(\delta+\mu+\gamma)}{qI^{**}} - \left( \frac{Z^{**}l(\delta+\mu+\gamma)}{qI^{**}} \right)^2 \\
C_6 &= -\frac{gi^2}{(y+i)^2} \\
C_6 &= -\left( \frac{qgI^{**}-Z^{**}l(\delta+\mu+\gamma)}{qI^{**}} \right)^2 \\
C_7 &= \frac{pmy^2}{(y+s)^2} \\
C_7 &= pm \left( \frac{qZ^{**}I^{**2}(\delta+\mu+\gamma)}{[Z^{**}(\delta+\mu+\gamma)+cqI^{**}][qgI^{**}-Z^{**}l(\delta+\mu+\gamma)]+qZ^{**}I^{**2}(\delta+\mu+\gamma)} \right)^2 \\
C_8 &= \frac{pms^2}{(y+s)^2} - \mu l \\
C_8 &= pm \left( \frac{[Z^{**}(\delta+\mu+\gamma)+cqI^{**}][qgI^{**}-Z^{**}l(\delta+\mu+\gamma)]}{[Z^{**}(\delta+\mu+\gamma)+cqI^{**}][qgI^{**}-Z^{**}l(\sigma+\mu+\gamma)]+qZ^{**}I^{**2}(\sigma+\mu+\gamma)} \right)^2 - \mu l \\
C_9 &= \frac{qgy^2}{(y+i)^2} \\
C_9 &= \left( \frac{Z^{**}l(\delta+\mu+\gamma)}{I^{**}} \right)^2 \\
C_{10} &= \frac{qgi^2}{(y+i)^2} \\
C_{10} &= \left( \frac{qgI^{**}-Z^{**}l(\delta+\mu+\gamma)}{I^{**}} \right)^2 \\
\det(JE_C) &= \begin{vmatrix} C_1 - \lambda & C_2 & C_3 & 0 \\ C_4 & C_5 - \lambda & C_6 & 0 \\ C_7 & 0 & C_8 - \lambda & \gamma l \\ 0 & C_9 & C_{10} & -(\sigma + \mu + \gamma)l - \lambda \end{vmatrix} = 0
\end{aligned}$$

$$\begin{aligned}
(7) \quad \det(JE_C) &= \lambda^4 + [(\sigma + \mu + \gamma)l - C_1 - C_5 - C_8]\lambda^3 \\
&+ [C_1C_5 + C_1C_8 + C_5C_8 - C_2C_4 - C_3C_7 - \gamma l C_{10} - (\sigma + \mu + \gamma)l(C_5 - C_8 - 1)]\lambda^2 \\
&+ [(C_2C_4C_8 + C_3C_7C_5 - C_1C_5C_8 - C_2C_6C_7) + \gamma l(C_1C_{10} + C_5C_{10} - C_6C_9) \\
&+ (\sigma + \mu + \gamma)l(C_1C_5 + C_1C_8 + C_5C_8 - C_3C_7 - C_2C_4)]\lambda \\
&+ [(\sigma + \mu + \gamma)l(C_2C_4C_8 + C_3C_5C_7 - C_2C_6C_7 - C_1C_5C_8) \\
&+ \gamma l(C_1C_6C_9 + C_2C_4C_{10} - C_3C_4C_9 - C_1C_5C_{10})]
\end{aligned}$$

The characteristic equation is of the form:  $\lambda^4 + b_1\lambda^3 + b_2\lambda^2 + b_3\lambda + b_4 = 0$ , where  $b_1 =$

$$[(\sigma + \mu + \gamma)l - C_1 - C_5 - C_8]$$

$$b_2 = [C_1C_5 + C_1C_8 + C_5C_8 - C_2C_4 - C_3C_7 - \gamma l C_{10} - (\sigma + \mu + \gamma)l(C_5 - C_8 - 1)]$$

$$b_3 = [(C_2C_4C_8 + C_3C_7C_5 - C_1C_5C_8 - C_2C_6C_7) + \gamma l(C_1C_{10} + C_5C_{10} - C_6C_9)$$

$$+ (\sigma + \mu + \gamma)l(C_1C_5 + C_1C_8 + C_5C_8 - C_3C_7 - C_2C_4)]$$

$$b_4 = [(\sigma + \mu + \gamma)l(C_2C_4C_8 + C_3C_5C_7 - C_2C_6C_7 - C_1C_5C_8)$$

$$+ \gamma l(C_1C_6C_9 + C_2C_4C_{10} - C_3C_4C_9 - C_1C_5C_{10})].$$
 By Routh stability criterion, the endemic equilibrium is stable if:

librium is stable if:

$$(i) \quad b_1 > 0 \text{ and } b_3 > 0$$

$$(ii) \quad b_1b_2b_3 > b_1^2b_4 + b_3^2$$

$$(iii) \quad b_4 > 0$$

Otherwise it is unstable.

## 6. Sensitivity analysis

In this section we carry out the sensitivity analysis to determine the responsiveness/robustness of the model, or otherwise to marginal changes in a parameter or group of parameters. This helps to identify whether a small change in any of the parameters that determine  $R_0$  will lead to

a greater effect in the prevalence of the infection. We perform the analysis by using the Forward Normalised Sensitivity Index (FNSI).

It is defined as follows:

Let  $R_0$  be a function that depends on  $x_i$ . Then the FNSI of  $R_0$  relative to  $x_i$  is given by

$$(8) \quad \Gamma_{R_0}^{x_i} = \frac{\partial R_0}{\partial x_i} \cdot \frac{x_i}{R_0}.$$

This index measures the relative change in  $R_0$  due to changes in  $x_i$ . It shows how significant each parameter is in determining the prevalence of the disease. Using the estimated parameter values,  $x_1 = r = 10.00$ ,  $x_2 = l = 0.95$ ,  $x_3 = p = 0.10$ ,  $x_4 = \mu = 0.01$ ,  $x_5 = m = 0.42$ ,  $x_6 = c = 0.02$  and  $x_7 = g = 1.20$ , the sensitivity indexes are calculated and indicated in table 1:

TABLE 1. Sensitivity indexes of  $R_0$

Parameter	Description	Value	Sensitivity Index
$l = \frac{1}{\beta K}$	$K =$ Environmental carrying capacity of susceptible prey and $\beta =$ Disease transmission rate among the prey	0.95	-1
$g = \frac{b}{\beta K}$	$b =$ Predation rate of infected prey	1.20	1
$c$	Death rate of infected prey	0.02	-1
$p$	Conversion rate of susceptible predator	0.10	0.3204
$m = \frac{n}{\beta K}$	$n =$ Predation rate of susceptible prey	0.42	-0.1806
$r = \frac{r_1}{\beta K}$	$r_1 =$ Logistic intrinsic growth rate of prey	10.00	-0.1398
$\mu$	Natural death rate of the predator	0.01	-0.0409

From Table 1, the most sensitive parameters are as  $l$ ,  $g$  and  $c$  as  $\Gamma_{R_0}^{x_i} = |1|$ . The implication is that an increase or decrease in either one or more of these parameters will have an increasing or decreasing effect on the prevalence of the disease. For example, an increase (decrease) in  $l$  by 10% will lead to a decrease (increase) of  $R_0$  by approximately 69% while an increase (decrease) in  $g$  by 10% will result in approximately 27% decrease (increase) in  $R_0$ .

Factors such as contact and/or predation rates greatly affect the disease transmission rate. Vaccination, quarantine and education are interventions for reducing the intra and inter disease transmission rates. However, these intervention strategy identified may not be feasible because of resource constraint. There is therefore the need to find the best ways of implementing these intervention to derive the best possible benefits with minimal cost.

## 7. Optimal controls analysis

In this section of the work, the aim is to incorporated in the initial model (2) some the identified interventions called control interventions to determine their impact on the disease transmission dynamics. These control interventions are:

- (i)  $u_1$ : the control variable based on quarantine of infected prey (Animals) and vaccination of susceptible prey(Animals).
- (ii)  $u_2$ : the control variable based on education and awareness of the disease by the predator (Human) as well as vaccination of susceptible predator(Human) for protection against the disease.
- (iii)  $u_3$ : the control variable due to the efficacy of the drug used for the treatment of infected predator(Human).

These interventions can be categorize into preventives and curatives. The control interventions such as quarantine, vaccination and education are preventives whilst treatment is curative. We therefore investigate the following control options to determine the best strategy:

- (i) **Strategy A:** Implementing the control aim at curing the infection,  
(ie.  $u_1 = u_2 = 0, u_3 \neq 0$ ).
- (ii) **Strategy B:** Implementing only the controls aim at preventing infection,  
(ie.  $u_1 \neq u_2 \neq 0, u_3 = 0$ ).
- (iii) **Strategy C:** Implementing all controls: (ie.  $u_1 \neq u_2 \neq u_3 \neq 0$ ).

With the incorporated controls, the basic model is given by:

$$(9) \quad \begin{cases} \frac{ds}{dt} = rs(1-s) - (1-u_1)si - \frac{msy}{y+s} \\ \frac{di}{dt} = (1-u_1)si - \frac{(1-u_2)giy}{y+i} - cli \\ \frac{dy}{dt} = \frac{pmsy}{y+s} - \mu yl + u_3 \gamma zl \\ \frac{dz}{dt} = \frac{(1-u_2)qgiy}{y+i} - (\sigma + \mu)zl - u_3 \gamma zl \end{cases}$$

The major objective here is to find the optimal levels of the intervention strategies desired to reduce the cost of implementation and hence the prevalence of the disease in both the predator(Human).

The related objective functional  $J$  is given by:

$$(10) \quad J = \text{Min}_{u_i, i \in [1,3]} \int_0^{t_f} (i + z + a_1 u_1^2 + a_2 u_2^2 + a_3 u_3^2) dt,$$

where  $a_i, i \in [1, 3]$  are non-negative weights associated with the controls. These measure the relative cost of implementing the interventions [3]. To minimize  $J(u_1, u_2, u_3)$  over the set of admissible controls  $U$  given by  $U = (u_1, u_2, u_3) | u_i$  are measurable with  $0 \leq u_i \leq 1$  for  $t \in [0, T]$ ,  $i=1,2,3$ , we find an optimal control triple  $(u_1, u_2, u_3)$

We apply Pontryagin's maximum principle (PMP) [10], which provides the necessary condition for optimality [3], to find the form of the optimal control of the model (9). This can be compared with the point-wise minimization of the Hamiltonian function  $H$  with respect to  $u_1, u_2$  and  $u_3$ .

$$(11) \quad H(u_i) = f(i, z, u, t) + \alpha X = i + z + a_1 u_1^2 + a_2 u_2^2 + a_3 u_3^2 \\ + \alpha_s \left( rs(1-s) - (1-u_1)si - \frac{msy}{(s+y)} \right) + \alpha_i \left( (1-u_1)si - \frac{(1-u_2)giy}{(y+i)} - cli \right) \\ + \alpha_y \left( \frac{pmsy}{(y+s)} - \mu ly + u_3 \gamma lz \right) + \alpha_z \left( \frac{(1-u_2)qgiy}{(y+i)} - (\sigma + \mu)lz - u_3 \gamma lz \right),$$

where  $\alpha_s, \alpha_i, \alpha_y$  and  $\alpha_z$  are the adjoint variables or co-state variables. By the PMP we have

**Proposition 1:** [12] *If the optimal triple  $(u_1^*, u_2^*, u_3^*)$  minimizes  $J(u_1, u_2, u_3)$  over  $U$  then there exists adjoint variables which satisfy the following:*

$$(12) \quad \begin{cases} \frac{d\alpha_s}{dt} = \frac{\partial H}{\partial s} = -\alpha_s r(2s-1) + (\alpha_s - \alpha_i)u_1 i + (\alpha_s - \alpha_y p) \frac{my^2}{(y+s)^2} \\ \frac{d\alpha_i}{dt} = \frac{\partial H}{\partial i} = (\alpha_s - \alpha_i)s + (\alpha_i - \alpha_s)u_1 s + \alpha_i c l - 1 + (\alpha_i - \alpha_z q) \frac{(1-u_2)gy^2}{(y+i)^2} \\ \frac{d\alpha_y}{dt} = \frac{\partial H}{\partial y} = (\alpha_s - \alpha_y p) \frac{ms^2}{(y+i)^2} + (\alpha_i - \alpha_z q) \frac{(1-u_2)gi^2}{(y+i)^2} + \alpha_y \mu l \\ \frac{d\alpha_z}{dt} = \frac{\partial H}{\partial z} = -1 - (\alpha_z + \alpha_i)u_3 \gamma l + \alpha_z l(\sigma + \mu) \end{cases}$$

Where  $\alpha_s(t) = \alpha_i(t) = \alpha_y(t) = \alpha_z(t)$  are the transversality conditions. The state and adjoint systems give the solution of the optimal control problem [11]. From equation (11) and by the stationary condition and after some algebraic manipulations, the optimal control triple is given as:

$$(13) \quad \begin{cases} u_1^*(t) = \min \left( 1, \max \left( \frac{(\alpha_i - \alpha_s)si}{2a_1}, 0 \right) \right) \\ u_2^*(t) = \min \left( 1, \max \left( (\alpha_z q - \alpha_i) \frac{giy}{2a_2(y+i)}, 0 \right) \right) \\ u_3^*(t) = \min \left( 1, \max \left( \frac{(\alpha_z - \alpha_y)\gamma lz}{2a_3}, 0 \right) \right) \end{cases}$$

## 8. Numerical simulation

In this section we present computer simulation of some solutions of the system. The purpose of numerical simulation is to verify the analytical results [3]. We therefore choose the following parameter values for the system (2) and (9):  $r = 10.00, l = 0.95, p = 0.10, c = 0.02, \mu = 0.01, m = 0, 42, g = 1.20, \gamma = 1.12, \sigma = 0.02, q = 0.05, a_1 = 30.00, a_2 = 20.00, a_3 = 10.00$  with initial valuea scaled to  $s(0) = 1.00, i(0) = 0.50, y(0) = 1.20, z(0) = 0.30$  per 10,000 individuals.

The results of the computer simulation and plots are as follows:

### Strategy A: Implementing the Control Aim at Curing the Infection



From (2) and (9) the following figures are generated.

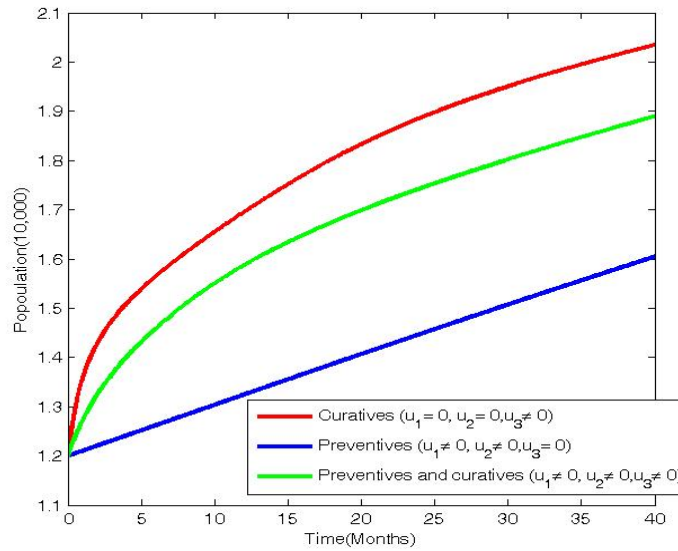

FIGURE 2. Susceptible Prey(Animals)

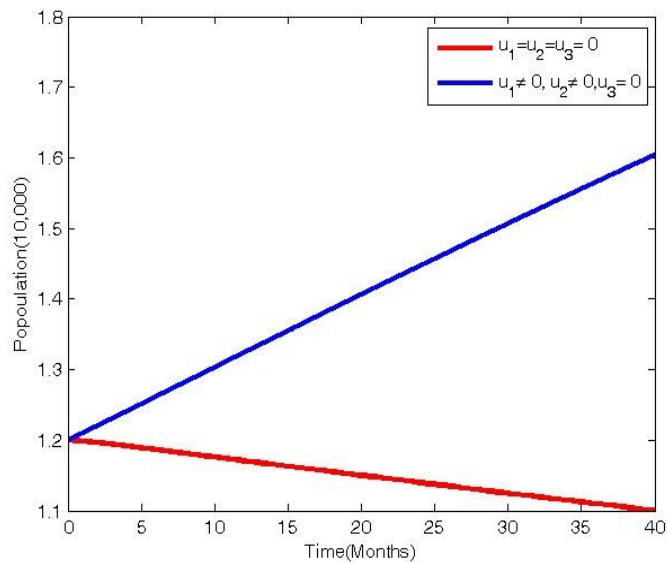

FIGURE 3. Infected Prey(Animals)

Figures 2, 3, 4, and 5 show the simulation results of the effect of control strategy A on the infection. The profile shows that implementing only control  $u_3$  has the ability to reduce the infected population and increase the susceptible population within a space of 40 months.

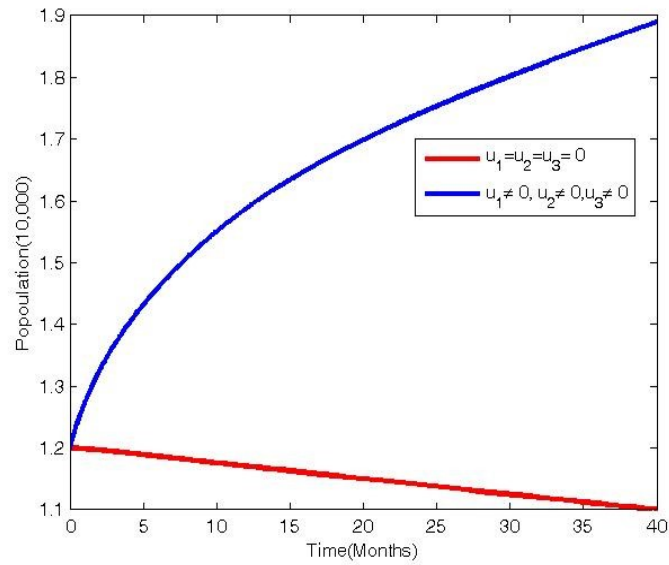

FIGURE 4. Susceptible Predator(Human)

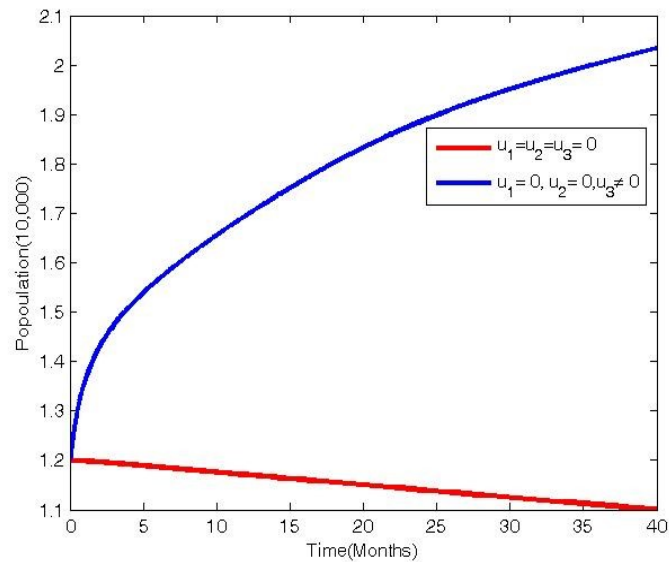

FIGURE 5. Infected Predator(Human)

**Strategy B: Implementing the Controls Aim at Preventing Infection**

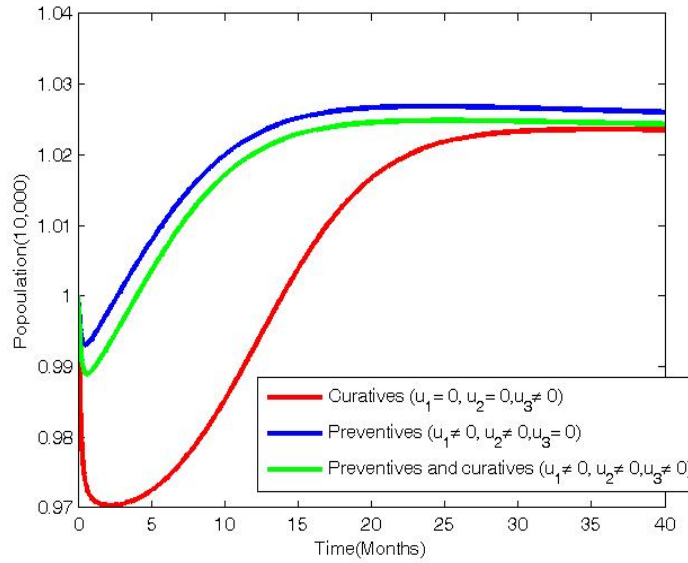

FIGURE 6. Susceptible Prey(Animals)

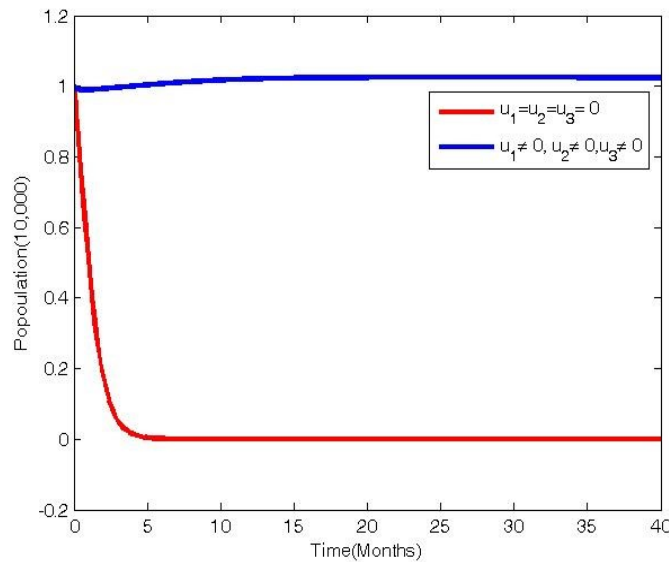

FIGURE 7. Infected Prey(Animals)

Figures 6, 7, 8 and 9 show the simulation results of the effect of control strategy B on the infection. This profile shows that implementing only controls  $u_1$  and  $u_2$  can reduce the infected population and increase the susceptible population within a space of 40 months.

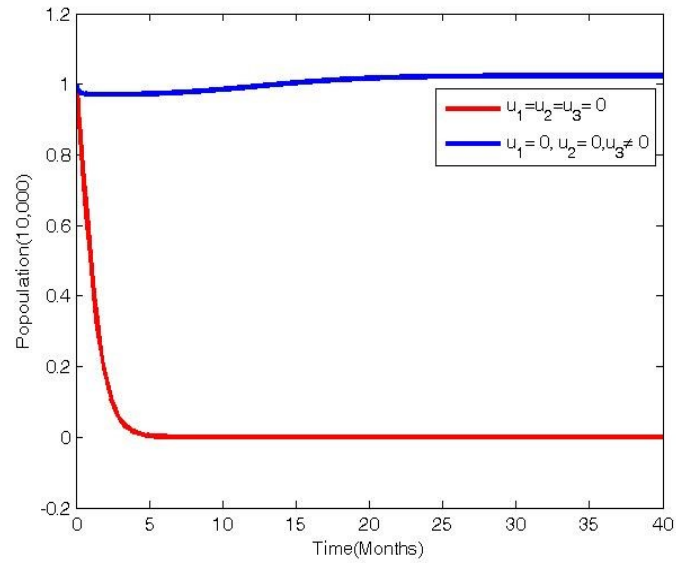

FIGURE 8. Susceptible Predator(Human)

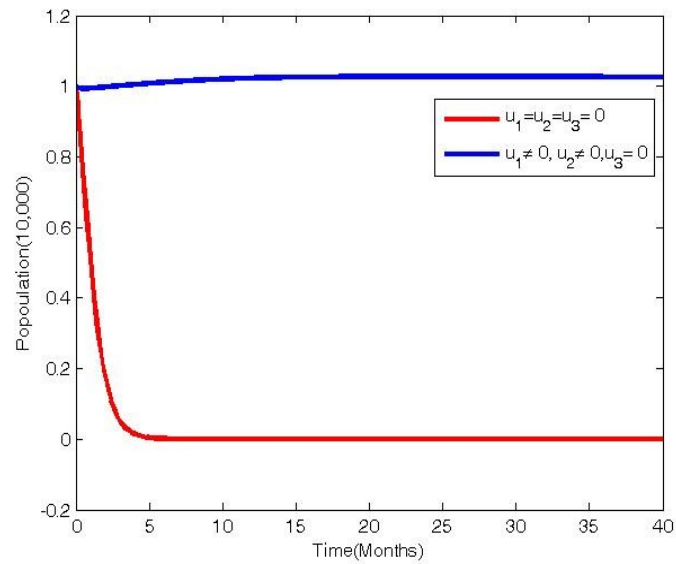

FIGURE 9. Infected Predator(Human)

**Strategy C: Implementing all Controls**

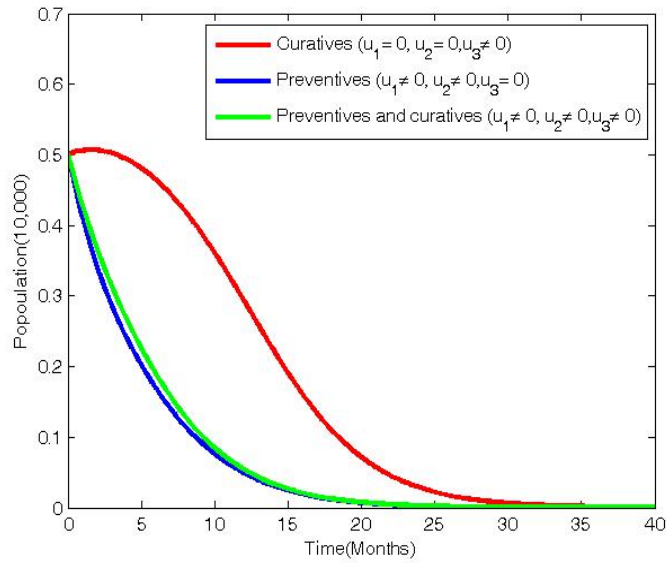

FIGURE 10. Susceptible Prey(Animals)

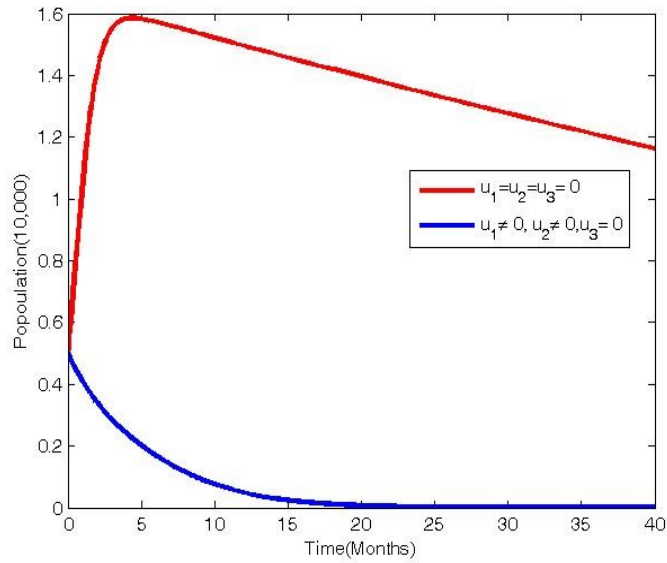

FIGURE 11. Infected Prey(Animals)

Figures 10, 11, 12 and 13 show the simulation results of the effect of control strategy C on the infection. This profile shows that implementing all the controls also have the ability to reduce the infected population and increase the susceptible population within a space of 40 months.

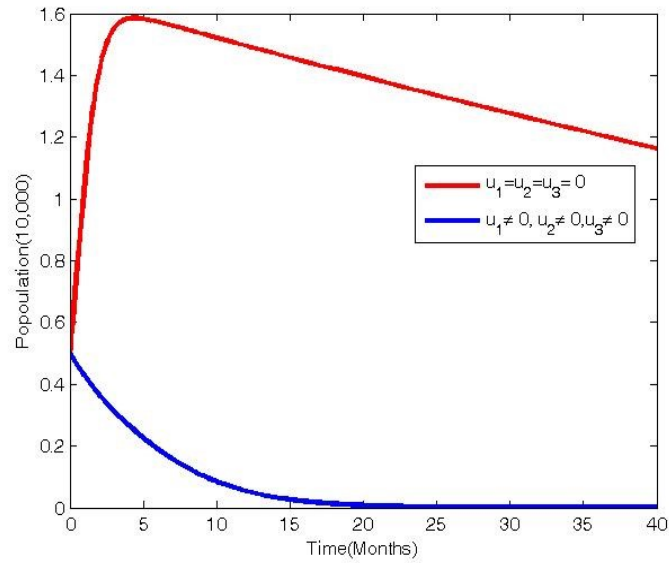

FIGURE 12. Susceptible Predator(Human)

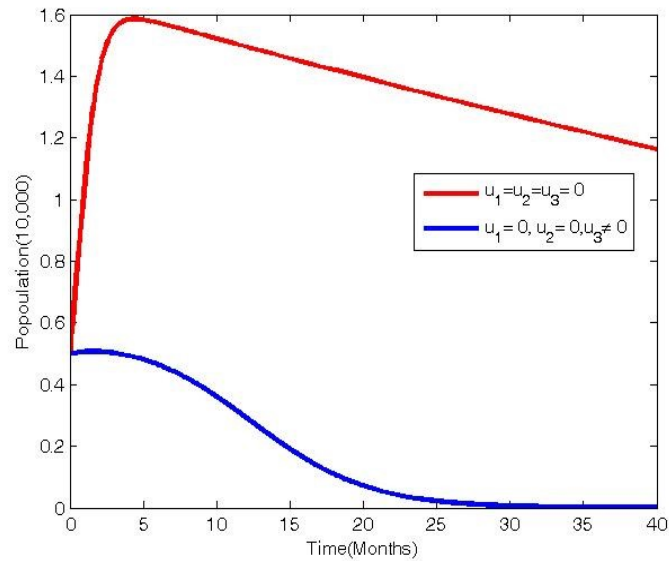

FIGURE 13. Infected Predator(Human)

The question at stake is which of these strategies is preferred in dealing with the infective and the susceptible populations? This gives the choice of the best possible strategy to implement.

### Comparing the Effects of the Strategies

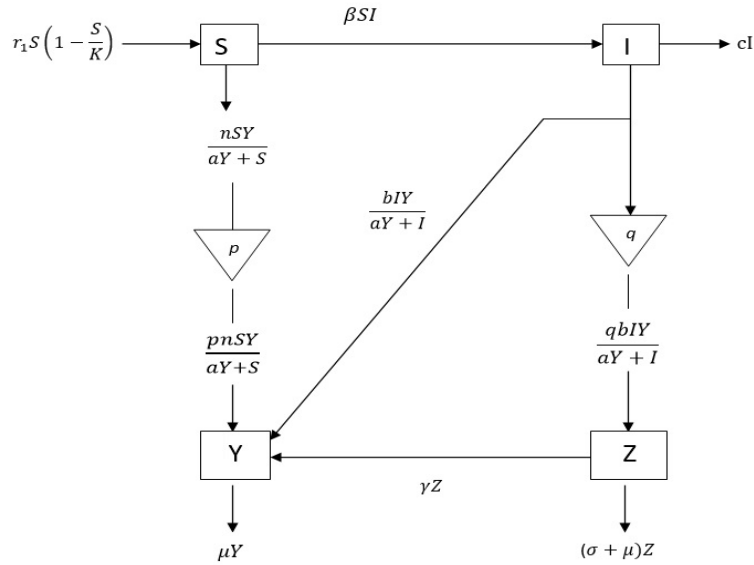

FIGURE 14. Susceptible Prey(Animals)

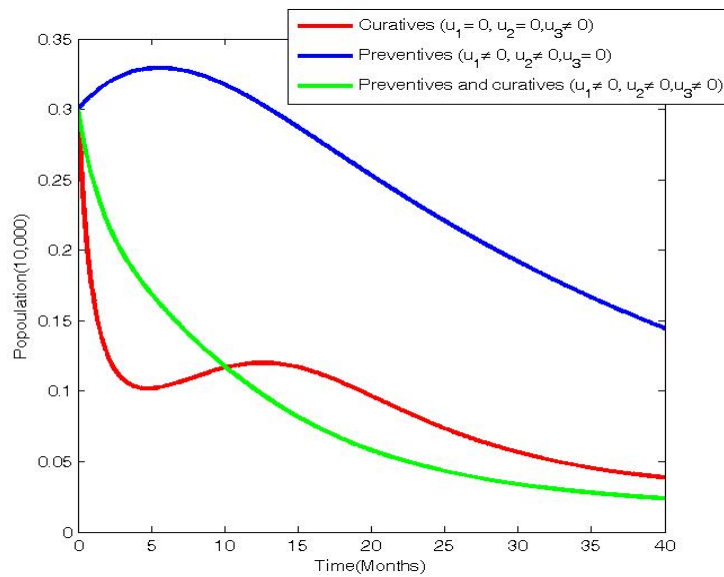

FIGURE 15. Infected Prey(Animals)

Figures 14, 15, 16 and 17 show the comparison of the effect of the control strategies on the infection.

- (i) Figure 14 indicates that the effect of preventives is higher by increasing the susceptible prey population, followed by the combined effect of the preventives and curatives.

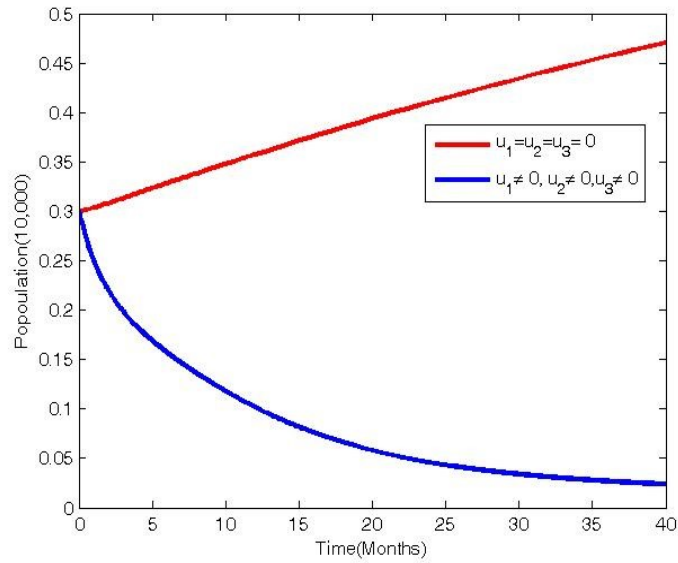

FIGURE 16. Susceptible Predator(Human)

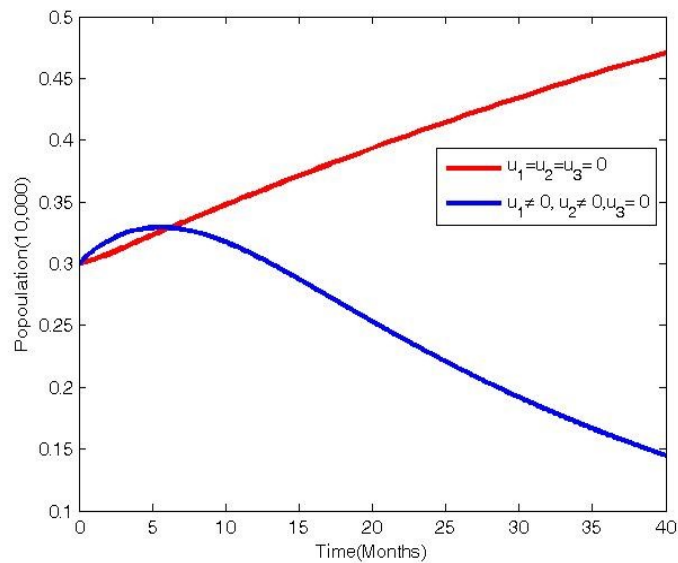

FIGURE 17. Infected Predator(Human)

- (ii) Figure 15 indicates that the effect of preventives is higher by reducing the infected prey population, followed by the combined effect of the preventives and curatives.
- (iii) Figure 16 indicates that the effect of curatives is higher by increasing the susceptible predator population, followed by the combined effect of the preventives and curatives.



- (iv) Figure 17 indicates that the effect of curatives is higher for ten 10 months after which the combined effect of the preventives and curatives prevailed for the rest of the 40 months period.

## 9. Cost-effectiveness analysis

This analysis seeks to highlight the control measure(s) that effectively manage the infection with minimum cost. This is because an effective strategy identified does not necessarily mean it is feasible on the grounds of the constraint of resources. Three major types of cost-effectiveness analysis ratios are identified:

- (i) Average Cost C Effectiveness Ratio (ACER): This compares a single intervention with a baseline practice, say no intervention. It looks at the net cost of the intervention as a ratio of the total number of infections effectively prevented by the intervention.
- (ii) Marginal Cost C Effectiveness Ratio (MCER): This deals with the additional change that occurs in the cost and effect as a result of an increase or decrease in the intervention by a specific level.
- (iii) Incremental Cost-Effectiveness Ratio (ICER): This also compares the costs of two alternative intervention strategies that are competing for the same resources with the number of infections controlled (i.e the additional cost per an additional infection controlled).

The main aim here is to compare the Cost-Effectiveness of three alternative interventions, curatives, preventives and both curatives and preventives. Hence the Incremental Cost C Effectiveness Ratio (ICER) is considered. This analysis is done to determine whether there will be additional benefits that will accrue in terms of lives gain as a result of applying the alternative interventions and at how much additional cost. It is the ratio of the change in costs to the change in the number of infections controlled due to the interventions.

To carry out this, we have to rank the strategies in ascending order by effectiveness of lives gained.

Table 2 shows the result of the analysis:

where

TABLE 2. Incremental Cost-effectives analysis

Alternative Interventions	Total Cost	Total Effect	Change in Cost	Change in Effect	ICER
Uncontrolled, $u_1 = u_2 = u_3 = 0$	0	0	0	0	
Preventives $u_1 \neq u_2 \neq 0, u_3 = 0$	44,505	14895	44505	14895	2.99
Curative $u_1 = u_2 = 0, u_3 \neq 0$	101,977	15949	57472	1054	54.53
Preventives and Curative $u_1 \neq u_2 \neq u_3 \neq 0$	49,558	16102	-52419	153	-4.19

$$ICER = \frac{\Delta C}{\Delta E}$$

$\Delta C$  = Change in Cost

$\Delta E$  = Change in Effect

From Table 2, the comparison between the preventives and the curatives show a cost saving of \$2.99 for preventives over the curatives. This indicates that the curative is more expensive and of less effectiveness than the preventive strategies. Therefore, curative is taken off from the set of alternatives to maximize the limited resources.

The comparison between the preventives and the combined effort of both preventives and curatives show a cost saving of -\$4.19 (negative) for the combined effort of both preventives and curatives over only preventives. This indicates that the combined effort is less expensive and of more effectiveness than only the preventive strategies. This is because the negative ICER for the combine effort of the strategies means there is an improvement in life-years and a reduction in costs. The ICER for preventives however works out to be positive (\$2.99), which means it costs \$2.99 to save an additional life-year.

## 10. Conclusion

In this study we formulated and analysed a nonlinear model to determine the transmission dynamics of infectious disease between human beings and animals in an eco-system. We equally established the existence of the equilibrium states and carried out a stability analysis of the equilibrium which shows that the infection can be managed if  $R_0 < 1$ . A sensitivity analysis of the basic reproduction number indicates that the rate of infection between the prey populations, the death rate of the infected prey and the rate of predation of the infected prey are the most sensitive parameters that can be used to control the spread of the infection. Therefore, it is advisable for policy makers to seriously consider these parameters in the fight against the infection.

In order to obtain a feedback from some interventions we carry out optimal control analysis based on preventive variables such as quarantining the infected prey and vaccinating the susceptible prey; creating awareness of the disease by educating and vaccinating the susceptible predator and a curative variable of drug treatment of the infected predator. Numerical analysis of the system shows an interesting result, which indicates that all the three strategies (preventives, curatives and a combined effort of both preventives and curative) have positive effects on the infection, however a further Cost-Effectiveness analysis reveals that the preventive strategy is better in combating the infection than the curative strategy. This conclusion is in line with a conclusion drawn by Okosun et al [11] who carried out an analysis of recruitment and industrial human resources management for optimal productivity in the presence of HIV/AIDS epidemic. It further indicates that a combined effort of both curatives and preventives is superior to the other strategies and therefore necessary to combat the disease. We sincerely hope that the application of this model will give a better understanding of how to successfully deal with zoonotic infection.

### Conflict of Interests

The authors declare that there is no conflict of interests.

## REFERENCES

- [1] D. Heymann, Control of Communicable Diseases Manual. American Public Health Association, Washington, 2004.
- [2] B. Mukhopadhyay and R. Bhattacharyya, Role of predator switching in an eco-epidemiological model with disease in the prey., Elsevier- Ecol. Model. 220 (2009), 931-939.
- [3] B. Seidu and O. D. Makinde, Optimal Control of HIV/AIDS in the Workplace in the Presence of Careless Individuals, Comput. Math. Method Medicine, 2014 (2014), Article ID 831506.
- [4] Y-H, Hsieh., C-K, Hsiao, Predator-prey model with disease infection in both populations, Math. Med. Biol. 25 (2008), 247-266.
- [5] A. Hugo, E. S. Massawe and O. D. Makinde, An eco-epidemiological mathematical model with treatment and disease infection in both prey and predator population, J. Ecology Natural Environment 4 (2012), 266-279.
- [6] R. Vardavas, R. Breban and S. Blower, Can influenza epidemics be prevented by voluntary vaccination?, PLoS Comp Biol., vol. 3:e85., 2007.
- [7] A. P. Galvani, T. C. Reluga and G. B. Chapman, Long-standing influenza vaccination policy is in accord with individual self-interest but not with the utilitarian optimum., Proc Natl Acad Sci USA 104 (2007), 5692-5697.
- [8] R. A. Saenz, H. W. Hethcote and G. C. Gray, Confined animal feeding operations as amplifiers of influenza. Vector Borne Zoonotic, Dis, 6 (2006), 338-346.
- [9] P. Van Den Driessche and J. Watmough, Reproduction numbers and sub-threshold endemic equilibria for compartmental models of disease transmission, Math. Biosci. 180 (2002), 29C48.
- [10] L. S. Pontryagin, The Mathematical Theory of Optimal Processes. vol. 4, CRC Press., 1962.
- [11] K. O. Okosun, O. D. Makinde and I. Takaidza, Analysis of recruitment and industrial human resources management for optimal productivity in the presence of the HIV/AIDS epidemic, J. Biol. Phy. 39 (2013), 99C121.